

YETI JR.™ ROCK RACER

1/18th SCALE ELECTRIC 4WD

READY-TO-RUN COMPLETE

ROCK RACER SERIES



 **axial**®
www.axialracing.com



CAUTIONS

 **To prevent serious personal injury and/or property damage, operate all remotely controlled models in a responsible manner as outlined herein.**

CHOOSE THE RIGHT PLACE TO OPERATE YOUR R/C MODEL.

- Do not run on public streets or highways. This could cause serious accidents, personal injuries, and/or property damage.
- Never run R/C models near people or animals.
- To avoid injury, do not run in confined spaces.
- Do not run where loud noises can disturb others, such as hospitals and residential areas.
- Never run indoors. There is a high risk of fire and/or damage.

INSPECT YOUR MODEL BEFORE OPERATION.

- Make sure that all screws and nuts are properly tightened. It is also a good idea to use removable thread lock wherever metal screws go into metal, especially for engine mounts and the engine pilot shaft.
- Always use fresh batteries for your transmitter and for your receiver to avoid losing control of the model.
- Always test the brakes and throttle before starting your engine to avoid losing control of the model.

AFTER OPERATION OF YOUR R/C MODEL

- Disconnect battery in vehicle first, then turn off transmitter, this will prevent runaways.
- Be careful when handling batteries, they will be hot after running.
- Replace any batteries that have been dented or have frayed wires, short circuits can cause fire.
- Be sure to keep your R/C model clean and free of excess dirt and grease, this will increase the life.

VORSICHT!

 **Um Verletzungen an Personen und/oder Sachschäden zu vermeiden, sollten alle ferngesteuerten Modelle sorgfältig und verantwortungsbewusst bedient werden, wie nachfolgend beschrieben.**

Wählen Sie den richtigen Platz zum Fahren

- Fahren Sie niemals auf öffentlichen Straßen. Dies könnte Verkehrsunfälle, Personen schäden oder Sachschäden verursachen.
- Fahren Sie niemals in der Nähe von anderen Personen oder Tieren.
- Fahren Sie niemals auf belebten Straßen.
- Fahren Sie nie in der Nähe von Wohnhäusern oder Krankenhäusern. Der Lärm könnte andere Personen stören.
- Fahren Sie niemals in Innenräumen. Dort könnte etwas beschädigt werden.

Überprüfen Sie Ihr Modell, bevor Sie es in Betrieb nehmen.

- Gehen Sie sicher, dass alle Schrauben und Muttern festgezogen sind. Verwenden Sie überall dort Schrauben-Sicherungslack, wo Metallschrauben in ein Metallgewinde greifen, besonders bei den Motorhaltern.
- Um Störungen zu vermeiden, benutzen Sie immer voll geladene Akkus in Ihrem Sender und Empfänger.
- Bevor Sie den Motor starten, sollten Sie immer die Funktion der Bremse und des Gashebels testen.

Nach Betrieb des RC Modells:

- Zuerst den Empfänger abdrehen, dann den Sender abdrehen um unkontrolliertes Durchgehen zu vermeiden.
- Seien Sie vorsichtig mit gebrauchten Akkus, sie können nach dem Gebrauch heiß sein.
- Ersetzen Sie Akkus/Batterien die beschädigt sind oder schadhafte Kabel aufweisen, sie können Kurzschlüsse oder Feuer verursachen.
- Halten Sie Ihr Fahrzeug sauber und entfernen Sie Schmutz und Schmierfett, damit erhöhen Sie die Lebensdauer Ihres Modells.

PRECAUTIONS

 **Afin d'éviter toutes blessures corporelles et/ou dommages environnants, veuillez procéder en toute responsabilité comme indiqué ci-dessous**

Choisir le lieu adéquat pour faire rouler votre modèle.

- Ne jamais rouler dans les rues ou sur les routes ouvertes au publique. Ceci peut provoquer de graves accidents.
- Ne jamais rouler près de personnes ou d'animaux.
- Pour éviter les blessures, ne pas rouler dans des espaces confinés.
- Ne jamais rouler où le bruit peut déranger, comme aux abords des hôpitaux ou des quartiers résidentiels.
- Ne jamais rouler à l'intérieur: les gaz d'échappement sont nocifs.

Controler votre modèle avant chaque utilisation.

- Vérifier que les vis et les écrous sont bien serrés. Il est très fortement conseillé d'utiliser du frein filet pour bloquer les vis qui sont en contact avec du métal et tout particulièrement les vis du moteur.
- Toujours utiliser des batteries bien chargées pour l'émission et la réception.
- Toujours vérifier les freins et la commande des gaz avant de démarrer.

Après l'Opération De Votre Modèle de R/C

- Le virage du récepteur premier, alors virage de l'émetteur, ceci empêchera des fugitifs.
- Faire attention en contrôlant des piles, ils auront chaud après avoir couru.
- Remplacer n'importe quelles piles qui ont été cabossées ou a éraillé des fils, les court-circuits peuvent causer le feu.
- Etre sûr de garder votre modèle de R/C nettoie et libère de terre et la graisse supplémentaires, ceci augmentera la vie.

Included items / Im Baukasten enthalten / Outils inclus dans le kit

Radio control car
Ferngesteuertes Modellauto
Voiture radio-commandée

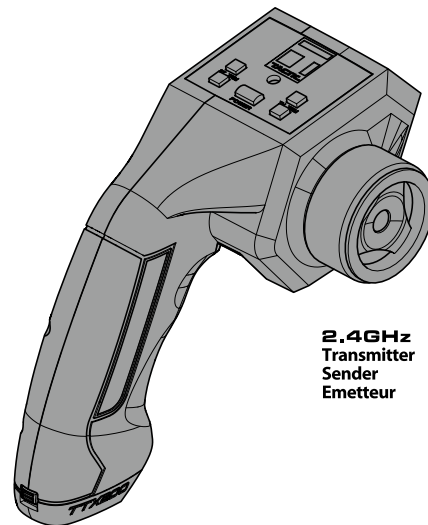
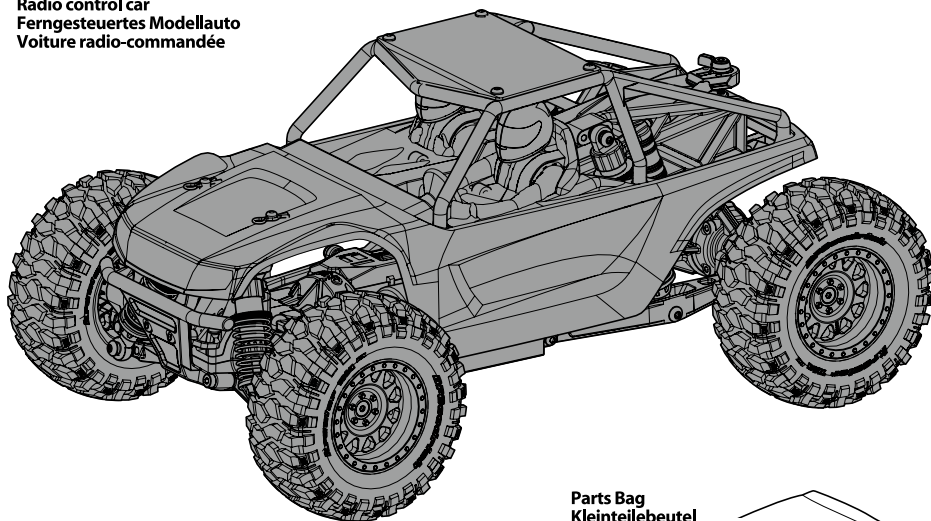

2.4GHz
Transmitter
Sender
Emetteur

Parts Bag
Kleinteilebeutel
Sachet de pièces détachées

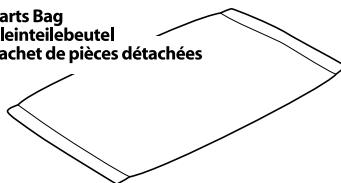

Cross wrench
Steckschlüssel
Clé à tube

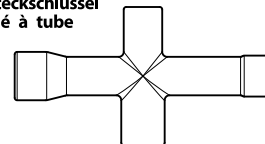

4 AA Alkaline Dry Batteries.
4 St. AA Trockenbatterien.
4 piles type R6 pour votre
radio commande.

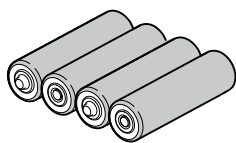

x4

Ni-MH Battery Pack
Akku-Pack
Pack de batterie

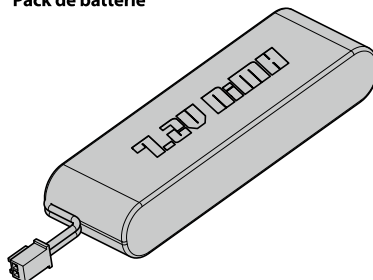

Charger
Ladegerät
Chargeur

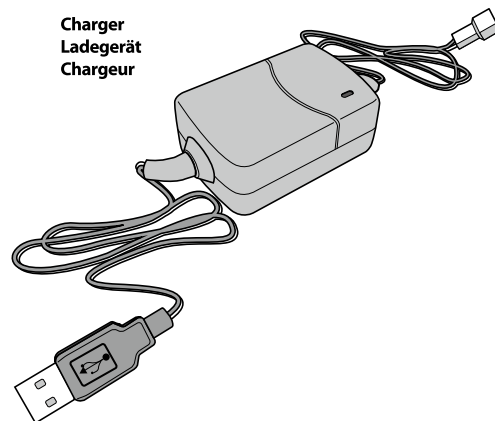

Tools Recommended / Benötigte Werkzeuge / Outillage

Hex wrench
Inbusschlüssel
Clé Allen

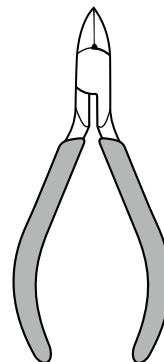
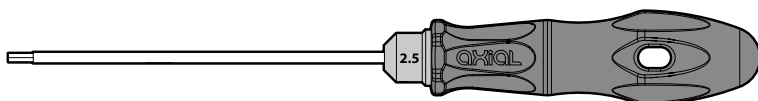
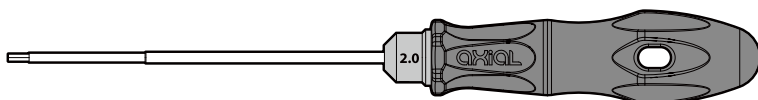
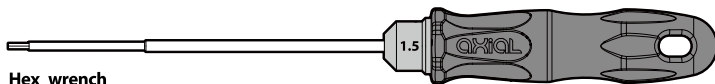

Side cutter
Seitenschneider
Pincès coupantes

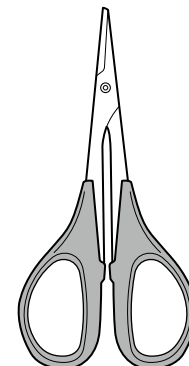

Curved scissors
Schere
Ciseaux

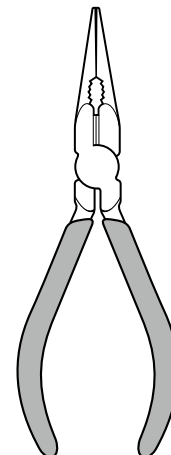

Long nose pliers
Flachzange
Pincès à becs longs

Modeling knife
Modelliermesser
Couteau de modéliste

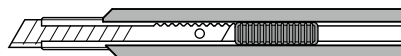

DTXP4175 USB NiMH Charger and DTXC2031 Battery Instructions

Before using your factory assembled RTR, review the entire instruction manual to become familiar with the vehicle. This is a quick start guide for care and usage of the charger and battery that comes with the vehicle.

DTXP4175 - Duratrax Onyx USB Charger

NiMH 6C Mini Connector

DTXC2031 - Duratrax NiMH Onyx 7.2V

1300mAh Flat Mini Connector

CAUTION: The DTXP4175 charger is for use with 6-Cell 7.2v NiMH batteries ONLY and should not be used with any other batteries.

CAUTION: Never leave the battery unattended while charging. Always disconnect the battery and unplug the charger when finished charging.

CAUTION HOT!!!

NiMH batteries may become hot while charging. Allow to cool before handling the battery.

- Remove the battery from the vehicle before charging.
- Place the battery on a fire resistant surface.
- Avoid any contact with water or other fluids.

1. Connect USB connector to USB power on PC or USB AC wall adapter.
2. Connect battery to mini connector.
3. Charger will automatically begin charge process.

Red LED: Charging
Green LED: Finish Charging

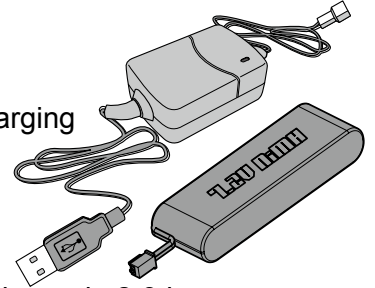

When using the DTXP4175 charger, the DTXC2031 battery should fully charge in 2-3 hours.

Getting Started / Anfängen Zu Werden / Commencer

① Remove the body clips and body.

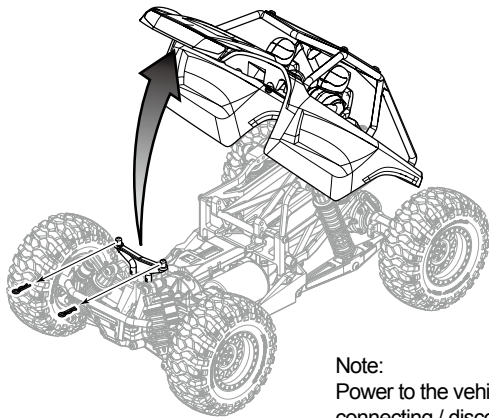

② Install the battery.

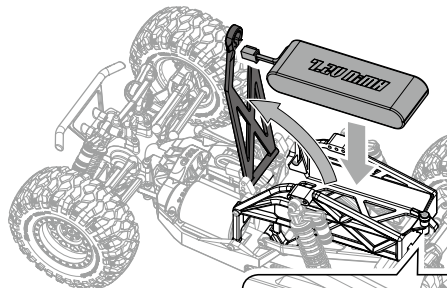

③ Turn on the transmitter.

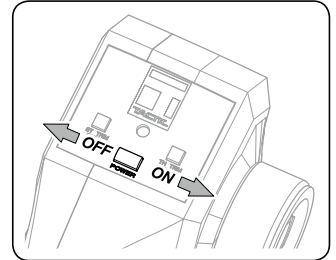

Note:
Power to the vehicle is controlled by connecting / disconnecting the battery.

④ Connect the battery to the ESC.

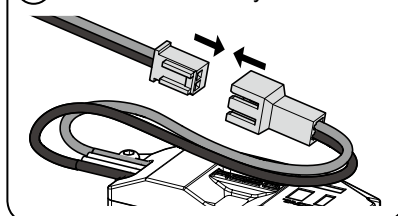

⑤ Install the body and body clips.

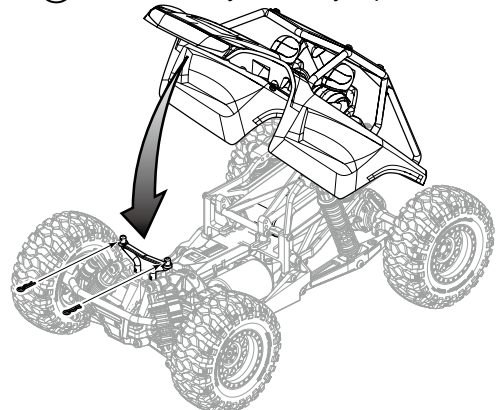

Top View Parts

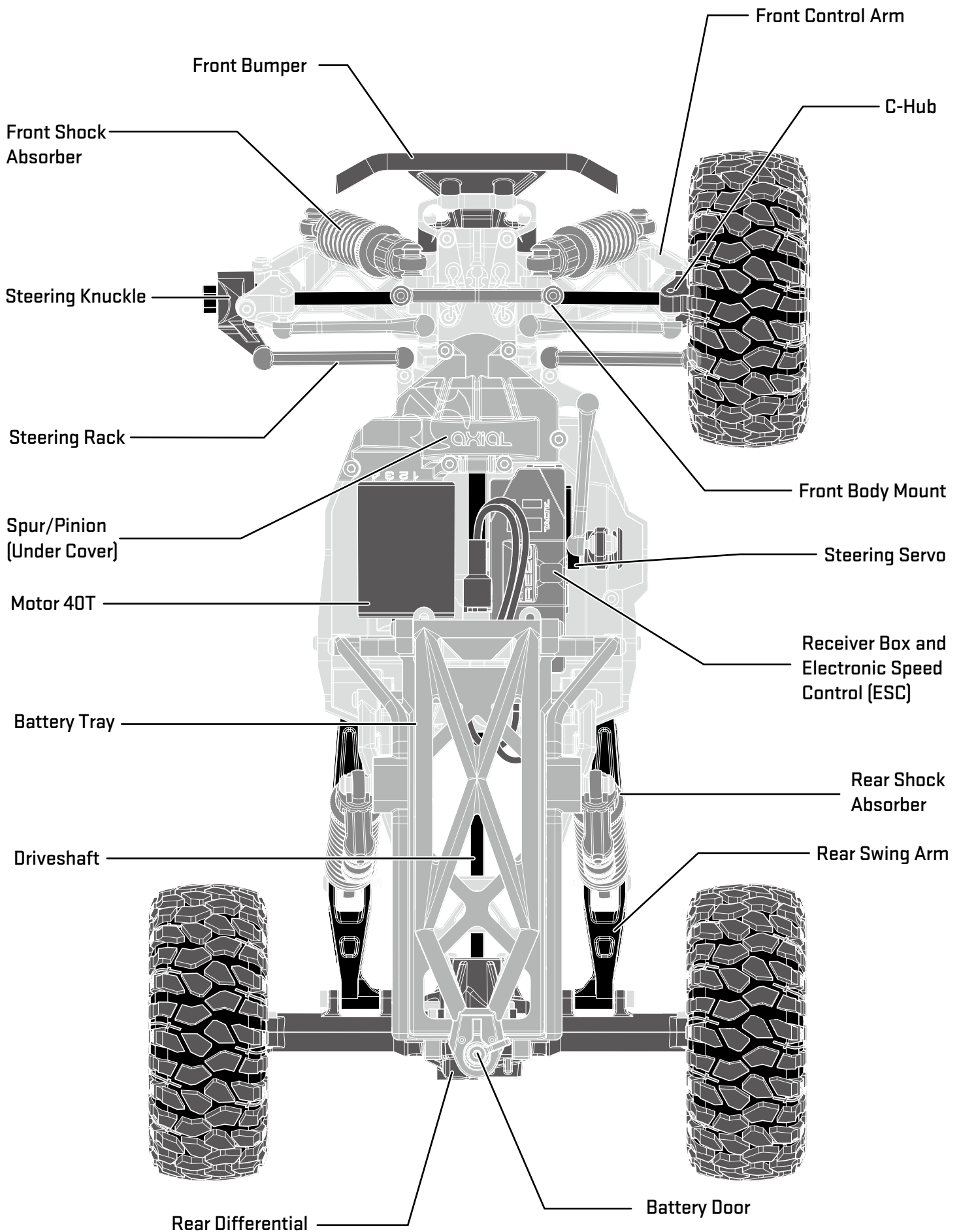

Getting-Started Checklist

The following checklist is a guide for getting you vehicle running for the first time.

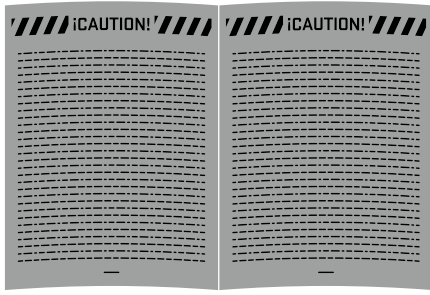

Read 'Cautions' in Manual. (Page 2)

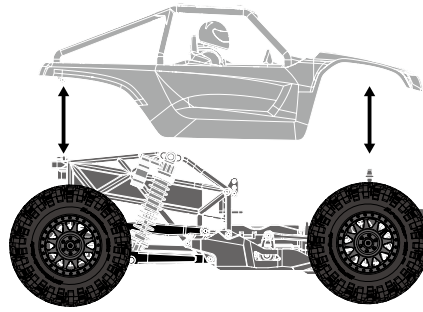

Familiarize yourself with vehicle and its components.

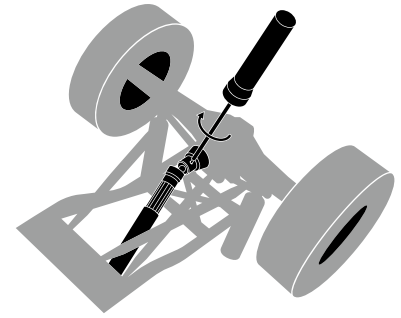

Before vehicle operation check all nuts and screws on moving parts are securely tightened.

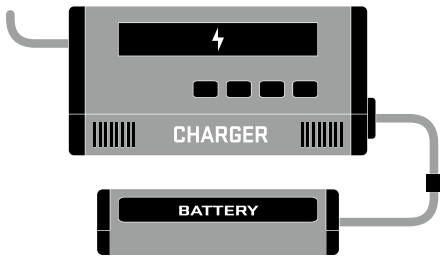

Charge battery pack. (Page 4)

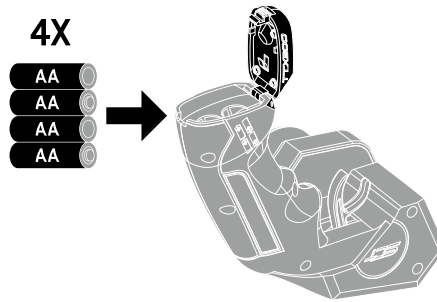

Install 4X AA batteries into Transmitter. (Page 7)

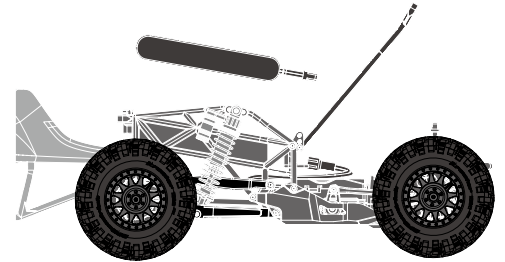

Install battery pack in vehicle. (Page 4)

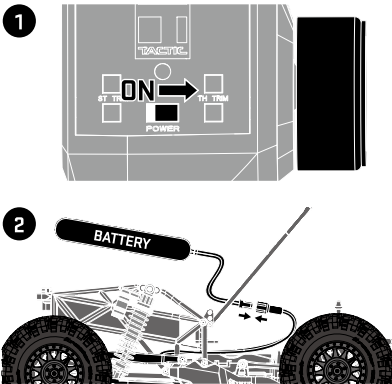

Turn on transmitter first, then plug in battery (power ESC) (Page 4)

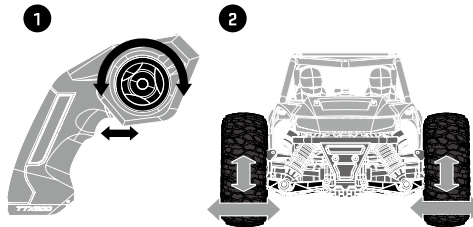

Check to make sure steering and throttle operation work correctly. (Page 7)



Range check radio system. (Next Page)

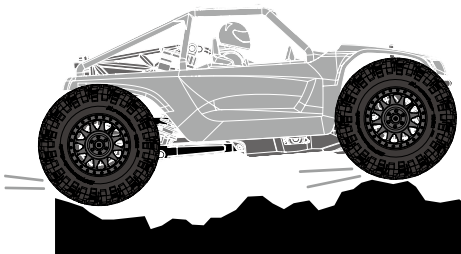

Drive vehicle, challenge yourself and have fun!

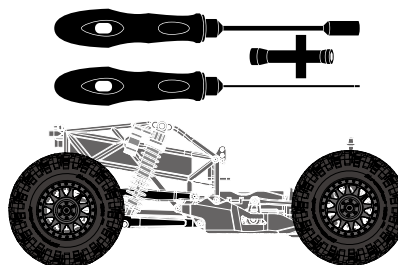

Maintain vehicle. (Next Page)

Range-Checking Your Radio System

The radio system should be checked before operating the vehicle to ensure it's operating properly and has adequate range.



1. Turn on the transmitter first and then the vehicle.
2. Have a friend hold the vehicle while keeping hands and loose clothing away from moving parts.
3. Walk away until you are at the farthest distance you plan to operate the vehicle.
4. Steer the vehicle back and forth and throttle both forward and reverse making sure there is no erratic behavior.
5. If any erratic behavior is exhibited do not operate the vehicle, call customer service for further assistance.



RANGE-CHECKING FOR DISTANCE

Maintaining Your Vehicle

Just like a full size car or truck your RC vehicle must undergo periodic maintenance in order to ensure peak running performance. Preventative maintenance will also help avoid needless breakages which could result in costly repairs. Below are some suggestions to properly maintain your vehicle.

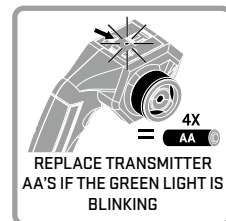
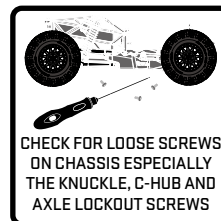
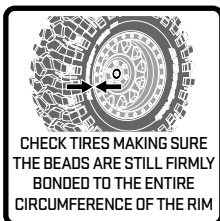
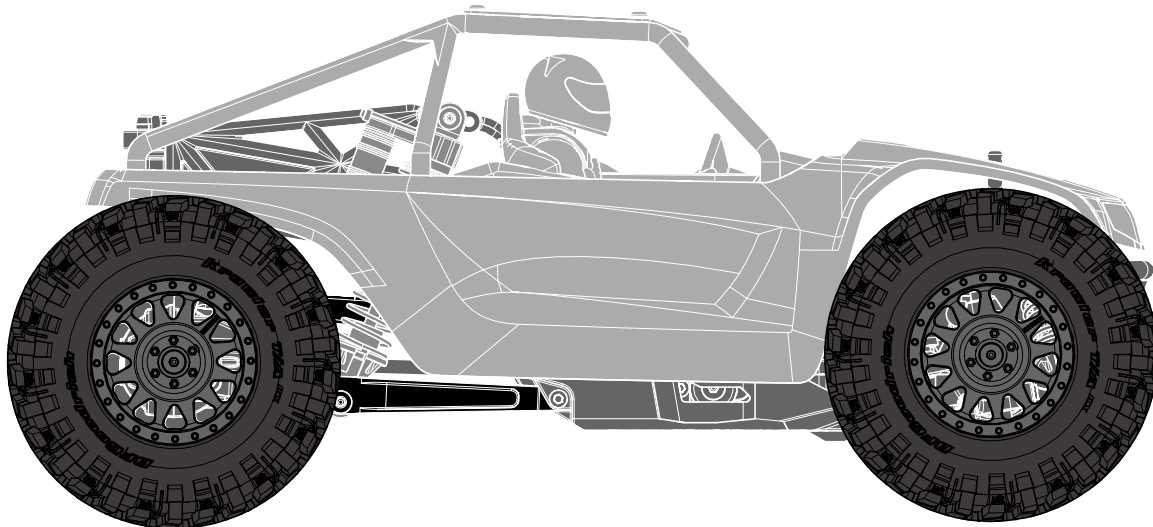
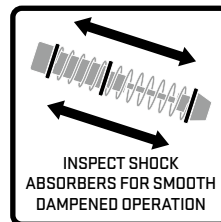
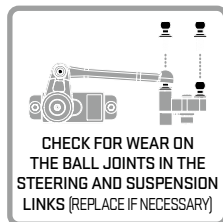
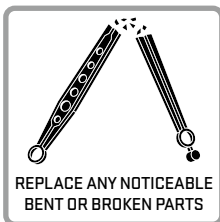

AXIAL LIMITED WARRANTY

Your Axial product is warranted to be free of defects in materials and workmanship when new in the factory sealed box. This warranty does not cover damages due to normal wear and tear, users' failure to perform routine maintenance, error of assembly or installation, modifications or addition of aftermarket parts or option parts. This warranty lasts as long as the original purchaser owns the product and is not transferable (verified by dated itemized sales receipt accompanied with product). In the event of a defect under this warranty, Axial will, at our discretion, repair or replace the product, provided our inspection indicates that an original defect exists. Axial provides a 10-day warranty from the date of purchase on electronics (i.e. servo, esc, radio). Axial reserves the right to replace any product which is no longer available with a product of comparable value and function. If Axial determines the repair is not covered under warranty guidelines, there could be a charge applied for the repair and return shipping charges. Note: Purchasing products from unauthorized distributors may void warranty and prevent support and service.

INTERNATIONAL CUSTOMER WARRANTY

Please return product to the dealer where the purchase was made. If your Axial product purchase was made through an on-line retailer, any warranty issues must be taken care of by that retailer. Axial assumes no responsibility for Axial products sold internationally by on-line retailers.

REPAIR

For warranty repair, please contact Axial Customer Service at (877) 64-AXIAL (877-642-9425).

HOURS AVAILABLE:

8:00 am - 5:00 pm Monday through Friday, Central Time.

Trouble Shooting / Fehlerbehebung / Dépannage

Problem Problem Problème	Cause Grund Cause	Remedy Lösung Remède
<p>Does not move Das Auto fährt nicht Le véhicule ne bouge pas</p>	<p>Batteries are not installed properly in the transmitter. Die Batterien sitzen nicht korrekt im Sender. Les piles ne sont pas placées correctement dans l'émetteur.</p> <p>Weak or no battery in model. Leerer oder kein Akku im Auto. Batterie faible ou non installée</p> <p>Damaged motor. Kaputter Motor. Moteur endommagé</p> <p>Frayed or broken wiring. Beschädigte Verkabelung. Câble dénudé ou coupe</p> <p>ESC is shut down by heat protection circuit. Notabschaltung des Reglers wegen Überhitzung. Le système ESC est fermé par le circuit de protection thermique.</p>	<p>Make sure batteries are properly installed. Legen Sie die Batterien korrekt ein. Positionnez correctement les piles dans l'émetteur.</p> <p>Install charged battery. Einbauen eines geladenen Akkus. Mettez en place une batterie chargée</p> <p>Replace with new motor. Austausch durch einen neuen Motor. Remplacez par un nouveau moteur</p> <p>Splice and insulate wiring completely. Erneuern und isolieren Sie die kaputte Stelle. Faites une épissure et isolez complètement le câble.</p> <p>Stop driving immediately, do not drive the car until the Speed Controller cools down. Fahren Sie nicht weiter. Warten Sie bis der Fahrten regler abgekühlt ist. Arrêtez immédiatement de conduire, ne pilotez pas la voiture tant que le contrôleur de vitesse n'a pas refroidi.</p>
<p>No Control. Keine Kontrolle über das Auto Pas de contrôle</p>	<p>Improper antenna on transmitter or model. Zu kurze Antenne am Sender oder Auto. Antenne inadéquate sur l'émetteur ou le véhicule</p> <p>Weak or no batteries in transmitter or model. Leere oder keine Batterien im Sender oder Auto. Batterie faible ou absente dans l'émetteur ou le véhicule.</p> <p>Neutral position or trim is incorrect. Neutralposition oder Trimmung sind verstellt. La position neutre est incorrecte ou le trim n'est pas réglé.</p> <p>Are the receiver and battery connections properly connected? Sind der Empfänger und die Batterieverbindungen ordentlich verbunden? Son conectadas apropiadamente las conexiones del receptor y la batería?</p>	<p>Install charged or fresh batteries. Einbauen voller Batterien. Mettez des batteries rechargées ou neuves.</p> <p>Fully extend antenna. Ziehen Sie die Antenne vollständig aus. Dépliez complètement l'antenne.</p> <p>Adjust the steering trim. Stellen Sie die Lenkungstrimmung neu ein. Réglez le trim de direction.</p> <p>Check receiver and battery connections. Prüfen Sie Empfänger und Batterieverbindungen. Compruebe conexiones de batería y receptor.</p>
<p>Steering and Throttle Function Reversed. Lenkung und Gas funktionieren genau verkehrt herum. Direction et accélération inverses.</p>	<p>Servo reverse switch is in wrong position. Servorichtungs-Schalter ist in der falschen Position. L'interrupteur de marche arrière du servo est dans la mauvaise position</p> <p>Please check that the wires from ESC to motor are connected properly. Bitte überprüfen Sie, ob die Kabel vom Regler zum Motor richtig sitzen. Veuillez vérifier que les fils allant de l'ESC au moteur sont correctement raccordés.</p>	<p>Set to correct position. Satz, Position zu korrigieren Vérifiez la position correcte</p> <p>Check to make sure motor and ESC are properly connected. Kontrolle sich zu vergewissern, dass Motor und ESC ordentlich verbunden sind. Le contrôle pour assurer que le moteur et ESC est convenablement connecté.</p>

TACTIC™

PURE RELIABLE 2.4

TTX200

TTX200

2.4GHZ RADIO CONTROL SYSTEM INSTRUCTION MANUAL

SLT™
SECURE LINK TECHNOLOGY

Thank you for making the Tactic TTX200 2.4GHz SLT system your choice for radio control! This system uses modern 2.4GHz Spread Spectrum technology—an innovation that allows for automatic channel selection and interference-free control of R/C models.



For safe operation and best results, it's strongly recommended to read this manual in its entirety before use! Also read and understand the instructions included with the model. Damage resulting from misuse or modification will void your warranty.

FEATURES

- 2.4GHz Spread Spectrum Technology
- Ergonomic and stylish case design
- Transmitter can bind to multiple receivers
- Built-in failsafe
- Steering and Throttle trim push-buttons
- Power LED with low battery warning indication
- Steering end point adjustment

TRANSMITTER

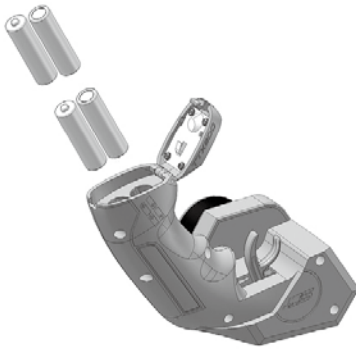

The transmitter (TX) requires four “AA” batteries. Non-rechargeable alkaline or rechargeable nickel-cadmium (NiCd) or nickel-metal hydride (NiMH) cells can be used. Do not mix old and new cells, or mix non-rechargeable alkaline cells with rechargeable NiCd or NiMH cells, etc. Note the TTX200 transmitter does not include a charge jack for rechargeable cells. A separate “AA” cell charger will be necessary.



IMPORTANT: Do not operate an R/C model with weak batteries as it could result in reduced range and/or possible loss of control!

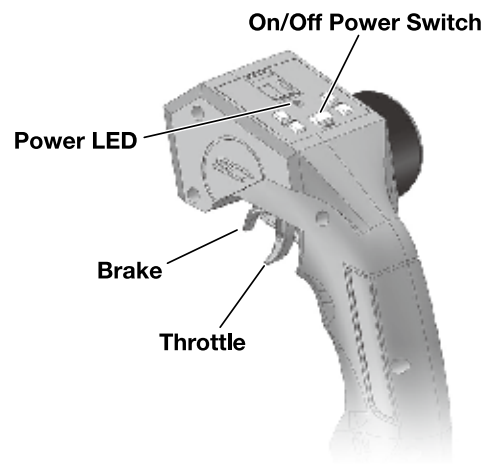
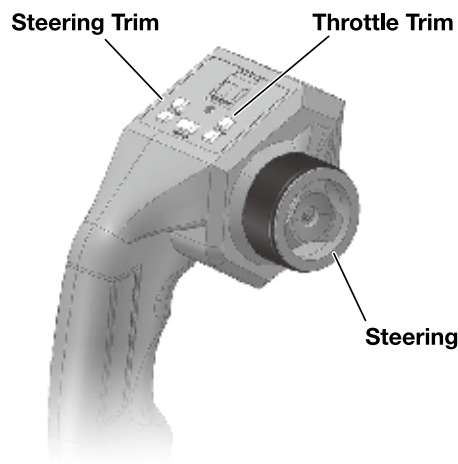

Slide the power switch to turn the TX on. The “POWER” LED should illuminate. If not, turn off the TX and check the batteries to make sure each cell is firmly in place and in the proper direction. If the TX LED blinks, the batteries are low on power and should be replaced.

LINK THE RE20 TO THE TRANSMITTER

The RE20 uses an auto-match process to link to the TTX200 or another Tactic transmitter. With the TTX200 and RE20 within 12 inches of each other, power on the TTX200 and then the RE20. Once the RE20 is powered up, it will auto-link to the nearest TTX200. The TTX200 and RE20 will come linked to one another from the factory. The red LED will glow solid when linked to the transmitter correctly. Perform a system check prior to using.

TTX200 PROGRAMMING

Several of the TTX200 features are adjusted electronically by following these steps:

REVERSE

Steering With the transmitter turned off, press and hold the top ST TRIM button and press the power button. The LED will flash one time to confirm when performed correctly.

Throttle With the transmitter turned off, press and hold the top TH TRIM button and press the transmitter's power button. The LED will flash one time to confirm when performed correctly.

STEERING END POINT ADJUSTMENT

With the transmitter turned on:

Left EPA Turn wheel FULL LEFT DIRECTION, use ST TRIM push buttons to adjust.

Right EPA Turn wheel FULL RIGHT DIRECTION CLOCKWISE, use ST TRIM push buttons to adjust.

RE20 PROGRAMMING

The RE20 programming is adjusted electronically by the TTX200.

BATTERY TYPE

When powering up RE20, the motor will beep according to which battery type setting it is programmed for. 2 beeps = NiMH, 3 beeps = LiPo. The default setting is NiMH (2 beeps).

To change battery type: First start with the TTX200 and RE20 powered OFF. Apply power to the RE20. Push and hold both ST TRIM buttons and turn ON the TTX200. The LED will flash to confirm. Release the buttons and the motor will beep in relation to its setting.

DRAG BRAKE

There are two settings for the Drag Brake: 1 = OFF, 2 = 50%. The default setting is OFF.

To change the drag brake setting: First start with the TTX200 and RE20 powered off. Apply power to the RE20. Push and hold both TR TRIM buttons and turn on the TTX200.

SYSTEM CHECK

Always turn on the Tx first, then the Rx. Make sure the steering servo operates according to the movement of the Tx controls.

STEERING

Turn the steering wheel left and right. Make sure there are no obstructions with the steering servo's movement, and the servo moves in the proper direction. If the steering wheel is turned to the right but the model turns left, reverse the steering channel (see TTX200 Programming).

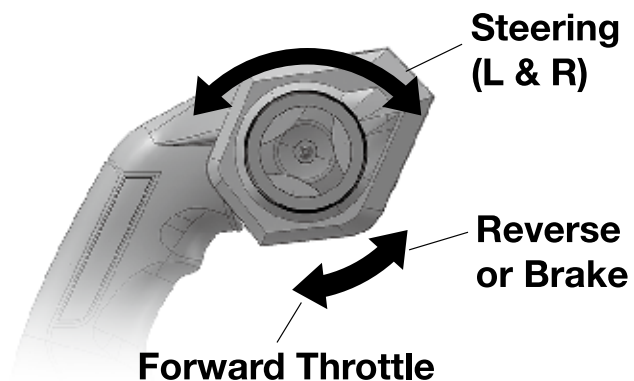

THROTTLE

Squeeze the throttle trigger to make the car move forward. If the car moves backwards, reverse the throttle channel (see TTX200 Programming).

FAILSAFE

This radio system includes a “fail-safe” function, which will automatically center (bring to neutral) all servos if the RE20 loses signal communications from the transmitter. When the RE20 regains signal it will automatically resume normal function.

RANGE CHECK

The “range” or safe operating distance from the TTX200 to the RE20 is typically as far as you can clearly see the model. Before operating the model, perform a simple range check to make sure the transmitter maintains good radio contact with the receiver within your operating area.

SAFETY PRECAUTIONS



- NEVER allow water or moisture to make contact with the electronic components inside the TTX200, RE20, servos, switch harness, etc.! This could lead to failure or improper functionality of components and poor control of vehicle which could pose a safety hazard.
- NEVER operate R/C equipment if you are physically impaired as it could pose a safety hazard to yourself or others in the area.
- NEVER allow small children to operate/control model R/C equipment without the supervision of an adult.
- NEVER allow the transmitter’s throttle trigger to accidentally be moved away from the neutral position while the vehicle is powered up.
- Always range check the radio system before use.
- Always make sure that all transmitter movements operate all servos/motor properly in the model.
- Do not store your radio equipment in extremely hot or cold locations, in direct sunlight, or in locations with high humidity. Store R/C equipment in a cool and dry location.
- Do not allow chemicals to come in contact with any parts of the radio system. Substances such as glow fuel, gasoline, CA glue, etc. could permanently damage plastic parts of the radio system.
- If rechargeable batteries were installed in the transmitter, remove the batteries before placing the radio in long-term storage.

TROUBLESHOOTING

RANGE IS SHORT

Interference – Check RE20 installation and servo connection.

Low TX or RX Battery – Replace the batteries or recharge if applicable.

Crash Damage – Send the radio to Hobby Services for repair.

RUN TIME IS SHORT

Low TX or RX Batteries – Replace the batteries.

Obstructed Servo Linkages

Causing Excess Battery Drain – Free the linkages/pushrods.

TX POWER SWITCH ON BUT SERVO DOES NOT FUNCTION

TX or RX Batteries are Low – Replace the batteries or check TX or RX battery polarity. Check servo and motor connections.

INTERFERENCE OR SERVOS GLITCHING

Out of Range – Operate the model more closely to the transmitter.

Outside Radio Interference – Check your local R/C club for confirmation (pagers, strong industrial or other commercial TXs in the area) of dangerous/interfering frequencies in your area.

CONTROL SURFACE MOVES IN THE WRONG DIRECTION

Channel Reverse Error – Follow the steps in the TTX200 section to reverse the channel.

STEERING SERVO GLITCHES

Servo is Bad – Replace the servo or send to Hobby Services for repair.

Contact Hobby Services for other problems.

TTX200 SPECIFICATIONS

TRANSMITTER

Channels: 2

Frequencies: 2.403-2.480GHz

Protocol: Tactic SLT

Modulation: FHSS spread spectrum

Input Power: 3.40-7.00V DC, four 1.5V alkaline or 1.2V NiCd/NiMH "AA" single cells.

Output Power: <0.1W

Power On Indicator: red LED

RE20

Channels: 2

Receiving Frequencies: 2.403-2.480GHz

Modulation: FHSS spread spectrum

Input Power: 6.0-8.4V

Dimensions: .256" x 0.94" x 1.14"
(65 x 24 x 29mm)

Weight: 0.6oz (16.7g)

FCC STATEMENT

This device complies with part 15 of the FCC rules. Operation is subject to the following two conditions.



- (1) This device may not cause harmful interference.
- (2) This device must accept any interference received, including interference that may cause undesired operation.

FCC Rf Radiated Exposure Statement: The equipment complies with FCC Rf radiation exposure limits set forth for an uncontrolled environment. This

equipment should be installed and operated with a minimum distance of 20 centimeters between the radiator and your body.

NOTE: THE MANUFACTURER IS NOT RESPONSIBLE FOR ANY RADIO OR TV INTERFERENCE CAUSED BY UNAUTHORIZED MODIFICATIONS TO THIS EQUIPMENT. SUCH MODIFICATIONS COULD VOID THE USER'S AUTHORITY TO OPERATE THE EQUIPMENT.

ACCESSORIES AND OTHER ITEMS

Stock #	Description
DTXP4704	Onyx AA Alkaline Battery (4)
DTXP4191	Onyx 110 AC/DC Peak Charger
TACJ0300	TTX300 3CH 2.4GHz Pistol Tx Rx
TACL0325	TR325 3CH 2.4GHz Receiver Only
TACL0326	TR326 3CH 2.4GHz RX Only HV

CE COMPLIANCE INFORMATION FOR THE EUROPEAN UNION

INSTRUCTIONS FOR DISPOSAL OF WASTE EQUIPMENT BY PRIVATE USERS IN THE EUROPEAN UNION:

This symbol on the product or its packaging indicates this product must not be disposed of with other household waste. Instead, it is the user's responsibility to dispose of their waste equipment by handing it over to a designated collection point or the recycling of waste electrical and electronic equipment. The separate collection and recycling of your waste equipment at the time of disposal will help to conserve natural resources and ensure that it is recycled in a manner that protects human health and the environment. For more information about where you can drop off your waste equipment for recycling, please contact your local city office, your household waste disposal service or location where you purchased the product.



DECLARATION OF CONFORMITY:

Product: Tactic TTX200 2.4GHz 2-Channel
Pistol TX

Item Number: TACJ0220

Equipment Class: 1



TACTIC TTX200 TRANSMITTER AND TACTIC RE20 RX/ESC 2IN1

The objects of the declaration described here are in conformity with article 3.1(a) the requirements of safety contained in the European 2006/95/EC Directive and article 3.1(b) the requirements of EMC contained in Directive 2004/108/EC and article 3.2 requirements of radio equipment in Directive 1999/5/EC.

EN 60950-1:2006 + A11:2009 + A1:2010 + A12:2011

ETSI EN 300 328 V1.8.1

ETSI EN 301 489-1 V1.9.2 (2011-09)

ETSI EN 301 489-17 V2.2.1 (2012-09)

ETSI EN 62311:2008

US standard: FCC 15.247
Japan standard: ARIB STD-T66
Canada standard: RSS210&RSS GEN
Product name: TTX200
Product type: TACJ0220
Brand: Tactic

Tactic
c/o Hobbico, Inc.
2904 Research Road
Champaign, IL USA 61826

INDUSTRY CANADA NOTICE

This device complies with Industry Canada license-exempt RSS standard(s).
1. Operation is subject to the following two conditions: (1) this device may not cause interference, and (2) this device must accept any interference, including interference that may cause undesired operation of the device. 2. Changes or modifications not expressly approved by the party responsible for compliance could void the user's authority to operate the equipment.

This equipment complies with IC radiation exposure limits set forth for an uncontrolled environment. In order to avoid the possibility of exceeding the IC radio frequency exposure limits, Human proximity to the antenna shall not be less than 20cm (8 inches) during normal operation.

Avis d'Industrie Canada

Le présent appareil est conforme aux CNR d'Industrie Canada applicables aux appareils radio exempts de licence. L'exploitation est autorisée aux deux conditions suivantes : (1) l'appareil ne doit pas produire de brouillage, et (2) l'utilisateur de l'appareil doit accepter tout brouillage radioélectrique subi, même si le brouillage est susceptible d'en compromettre le fonctionnement. Cet appareil numérique ne dépasse pas les Rèlements sur l'interférence radio par un appareil numérique de classe B stipulées dans les Règlement sur l'interférence radio d'industrie Canada.

2. Les changements ou modifications de cette unité non expressément approuvés par la partie responsable de la conformité pourraient annuler l'autorité de l'utilisateur à utiliser l'équipement.

IC RF Déclaration sur la radioexposition:

Cet appareil est conforme avec l'exposition aux radiations IC Définies pour un environnement non contrôlé. Les utilisateurs finaux doivent suivre les instructions de fonctionnement spécifiques pour satisfaire la conformité aux expositions RF.

TAIWAN NATIONAL COMMUNICATIONS COMMISSION (NCC) STATEMENT

根據NCC低功率電波輻射性電機管理辦法 規定:

1. 經型式認證合格之低功率射頻電機, 非經許可, 公司、商號或使用者均不得擅自變更頻率、加大功率或變更原設計之特性及功能。
2. 低功率射頻電機之使用不得影響飛航安全及干擾合法通信;經發現有干擾現象時, 應立即停用, 並改善至無干擾時方得繼續使用。
前項合法通信, 指依電信法規定作業之無線電通信。
低功率射頻電機須忍受合法通信或工業、科學及醫療用電波輻射性電機設備之干擾。

WARRANTY AND REPAIR

1-YEAR LIMITED WARRANTY

Tactic warrants this product to be free from defects in materials and workmanship for a period of one (1) year from the date of purchase. During that period, Tactic will, at its option, repair or replace without service charge any product deemed defective due to those causes. You will be required to provide proof of purchase (invoice or receipt). This warranty does not cover damage caused by abuse, misuse, alteration or accident. If there is damage stemming from these causes within the stated warranty period, Tactic will, at its option, repair or replace it for a service charge not greater than 50% of its then current retail list price. Be sure to include your daytime telephone number or e-mail address in case we need to contact you about your repair. This warranty gives you specific rights. You may have other rights, which vary from state to state.

For service on your Tactic product, send it post paid and insured to:

HOBBY SERVICES

3002 N. Apollo Dr., Suite 1
Champaign, IL 61822

Tel: (217) 398-0007

(9:00am - 5:00pm CST, M-F)

E-mail: hobbyservices@hobbico.com

*For warranty and service information if purchased outside the U.S.A. or Canada, ask your retailer for more information.

In the European Union, send it postpaid and insured to:

Service Abteilung Revell GmbH

Henschelstrasse 20-30
32257 Bünde Germany

Tel: 01805-110111 (nur für Deutschland)

E-mail: Hobbico-Service@Revell.de

Distributed in the EU by Revell GmbH, Bünde Germany

- This product is suitable only for people of 14 years and older. This is not a toy!
- **WARNING: CHOKING HAZARD** - May contain small parts. Keep away from children under 3 years. Please retain packaging for future reference.
- No part of this manual may be reproduced in any form without prior permission.
- The contents of this manual are subject to change without prior notice.
- Tactic is not responsible for the use of this product.

TACTICTM
PURE RELIABLE 2.4
ITX200

tacticrc.com

FCC ID: IYFTTX200

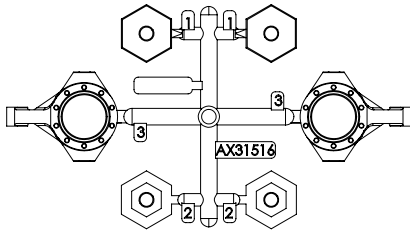

AX31516
Yeti Jr.™ Steering Knuckle Set **x1**

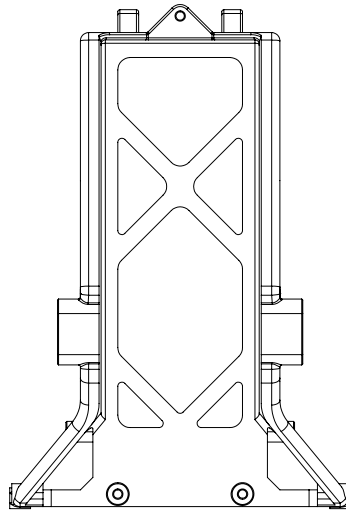

AX31508
Yeti Jr.™ Rear Cage Battery Tray **x1**

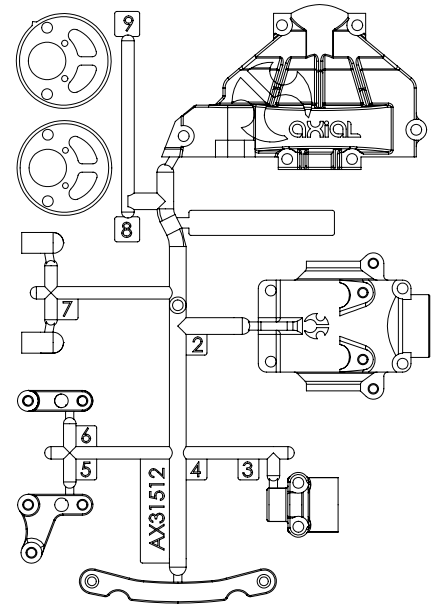

AX31512
Yeti Jr.™ Chassis Components **x1**

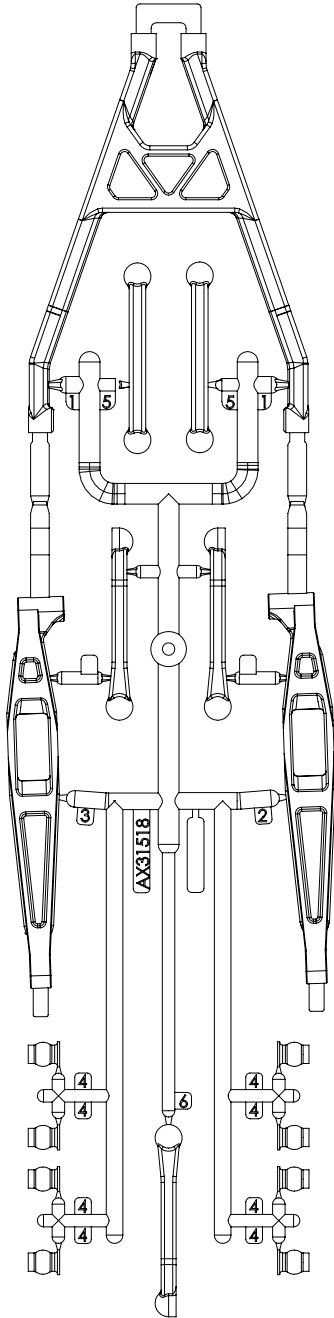

AX31518
Yeti Jr.™ Rear Axle Link Set **x1**

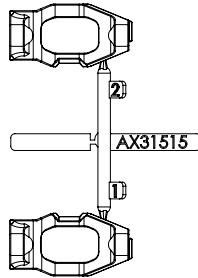

AX31515
Yeti Jr.™ Front Carrier Set **x1**

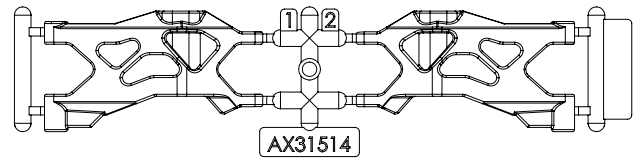

AX31514
Yeti Jr.™ Front Lower Control Arm Set **x1**

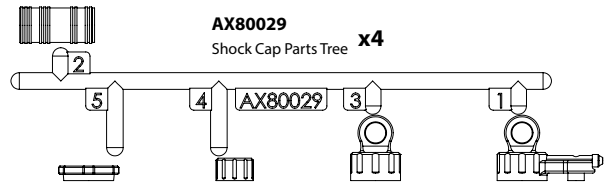

AX80029
Shock Cap Parts Tree **x4**

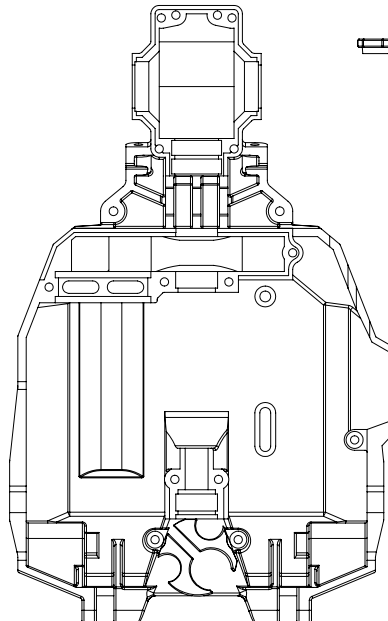

AX31506
Yeti Jr.™ Molded Chassis Tub **x1**

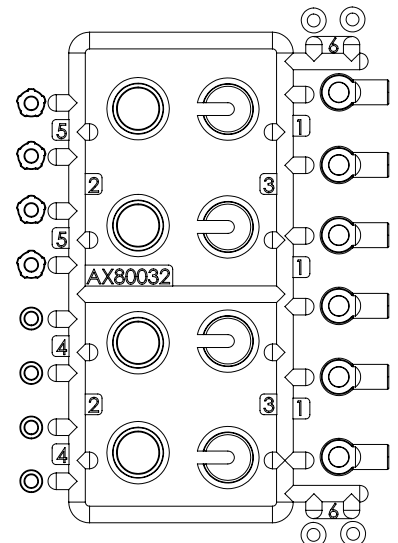

AX80032
Shock Parts **x2**

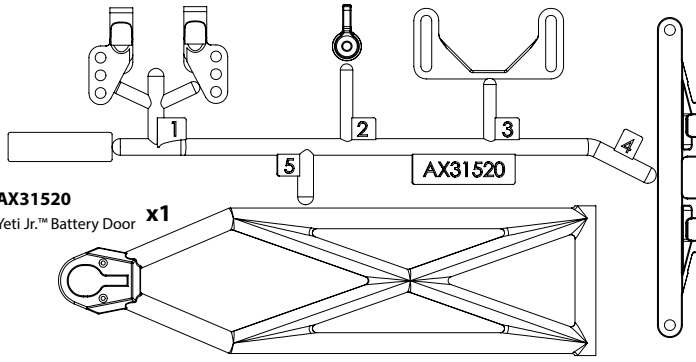

AX31520
Yeti Jr.™ Battery Door **x1**

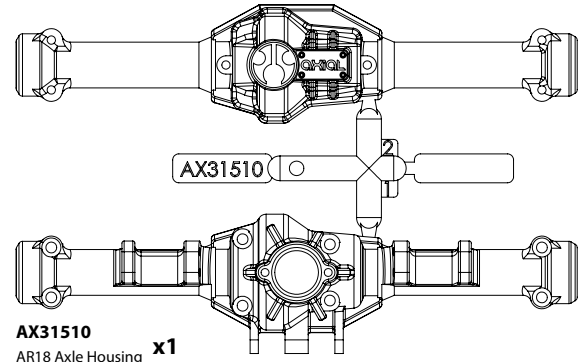

AX31510
AR18 Axle Housing **x1**

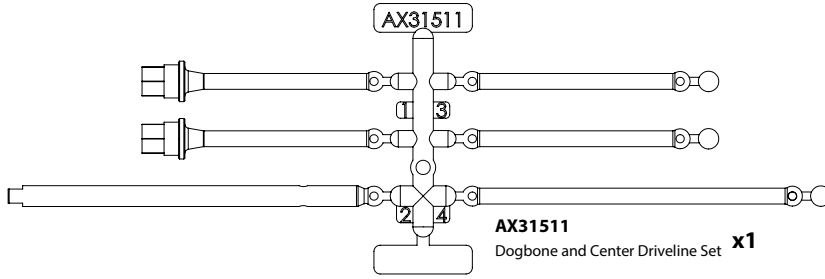

AX31511
Dogbone and Center Driveline Set **x1**

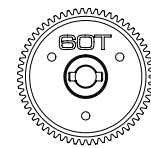

AX31513
Spur Gear 48P 60T **x1**

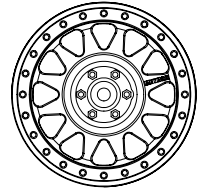

AX31522
1.55 Method Beadlock Style Wheels (Black) **x4**

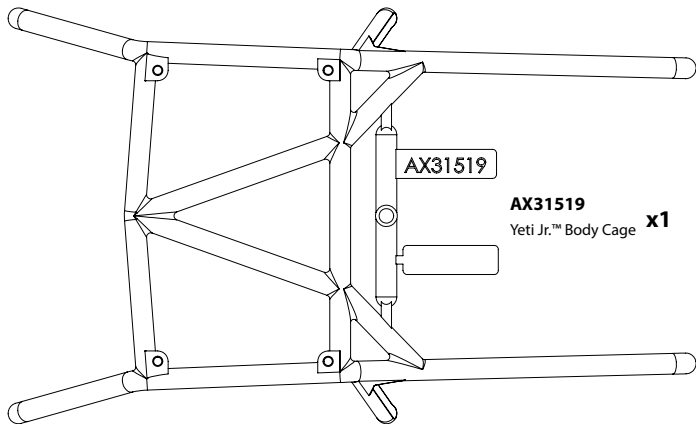

AX31519
Yeti Jr.™ Body Cage **x1**

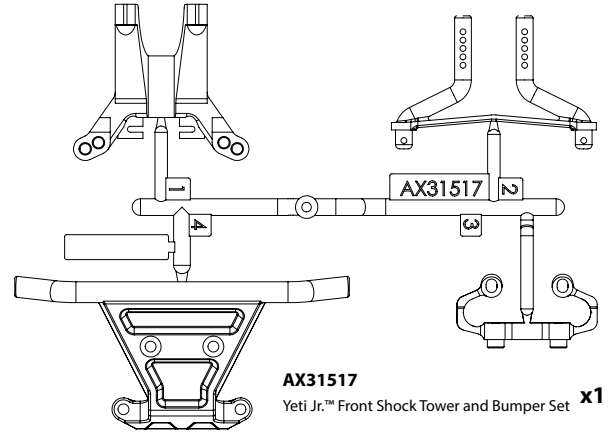

AX31517
Yeti Jr.™ Front Shock Tower and Bumper Set **x1**

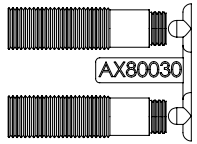

AX80030
61-90mm Shock Body Set **x1**

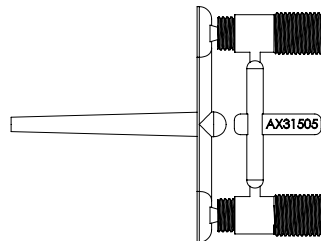

AX31505
46-63mm Shock Body Set **x1**

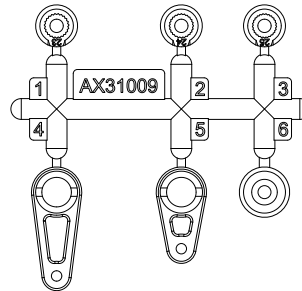

AX31009
Mini servo saver mold **x1**

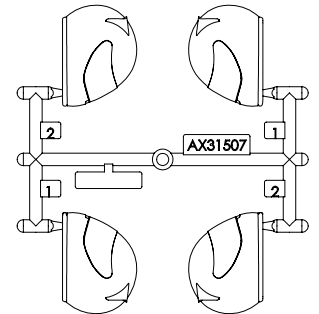

AX31507
Jr. Helmet Set (White) **x1**

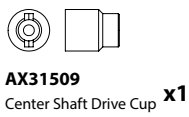

AX31509
Center Shaft Drive Cup **x1**



AX31509
Output Support Sleeve **x4**

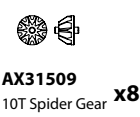

AX31509
10T Spider Gear **x8**

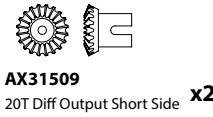

AX31509
20T Diff Output Short Side **x2**

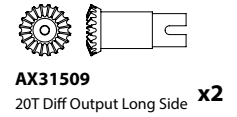

AX31509
20T Diff Output Long Side **x2**

AX31509
Differential Outputs Set **x1**

Parts Reference / Übersicht aller Teile / Référence des pièces



AXA013
M2x6mm Cap Head **x2**



AXA0023
M2.6x8mm Cap Head **x8**



AX31398
M2.6x12mm Cap Head **x4**



AX31399
M2.6x18mm Cap Head **x3**



AX31493
M2.6x25mm Cap Head **x1**

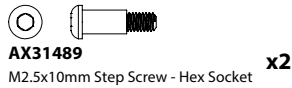

AX31489
M2.5x10mm Step Screw - Hex Socket **x2**

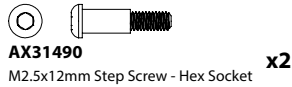

AX31490
M2.5x12mm Step Screw - Hex Socket **x2**



AX31499
Ball Stud 4mm **x10**

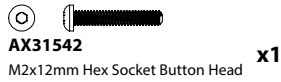

AX31542
M2x12mm Hex Socket Button Head **x1**

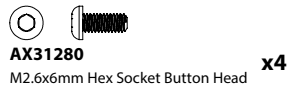

AX31280
M2.6x6mm Hex Socket Button Head **x4**



AXA0065
M2.6x10mm Hex Socket Button Head **x10**



AX31195
M2.6x12mm Hex Socket Button Head **x10**



AX31491
M2.6x18mm Hex Socket Button Head **x11**



AXA117
M3x15mm Hex Socket Button Head **x8**



AXA0422
M2.6x6mm Hex Socket Tapping Button Head **x4**



AXA0423
M2.6x8mm Hex Socket Tapping Button Head **x6**

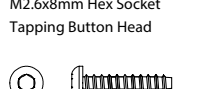

AXA0425
M2.6x12mm Hex Socket Tapping Button Head **x2**



AXA0413
M2.6x8mm Hex Socket Tapping Flat Head **x4**



AXA0414
M2.6x10mm Hex Socket Tapping Flat Head **x1**



AXA146
M3x12mm Hex Socket Flat Head **x2**



AXA147
M3x16mm Hex Socket Flat Head **x2**



AXA180
M3x3mm Set Screw **x1**



AXA1041
M2.5 Nylon Locking Hex Nut **x1**

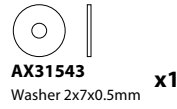

AX31543
Washer 2x7x0.5mm **x1**



AX31289
M8x10x0.3mm Shim **x4**

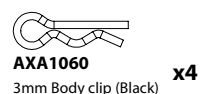

AXA1060
3mm Body clip (Black) **x4**

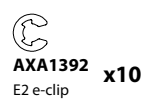

AXA1392
E2 e-clip **x10**



AXA1179
O-Ring 2.5x1.5mm **x8**

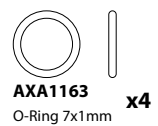

AXA1163
O-Ring 7x1mm **x4**

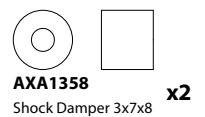

AXA1358
Shock Damper 3x7x8 **x2**

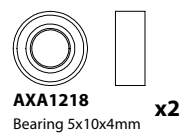

AXA1218
Bearing 5x10x4mm **x2**

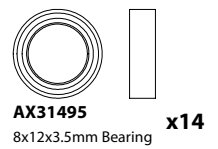

AX31495
8x12x3.5mm Bearing **x14**

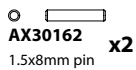

AX30162
1.5x8mm pin **x2**



AX30168
2x8mm pin **x1**



AX31497
2.0x20mm Pin **x4**

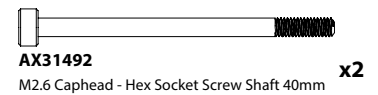

AX31492
M2.6 Cap Head - Hex Socket Screw Shaft 40mm **x2**

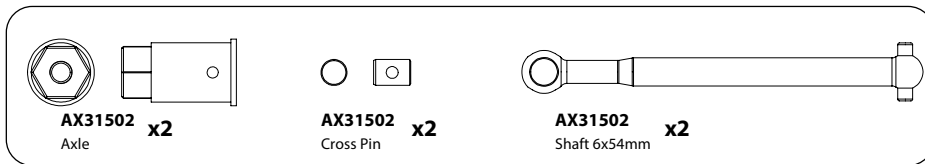

AX31502
Axle **x2**

AX31502
Cross Pin **x2**

AX31502
Shaft 6x54mm **x2**



AX31504
2.5mm shaft **x2**

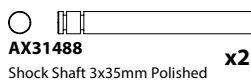

AX31488
Shock Shaft 3x35mm Polished **x2**



AX30146
Shock Shaft 3x50mm Polished **x2**

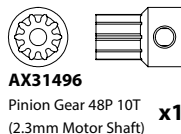

AX31496
Pinion Gear 48P 10T
(2.3mm Motor Shaft) **x1**

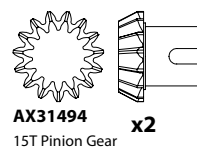

AX31494
15T Pinion Gear **x2**

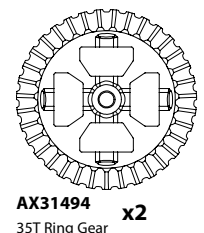

AX31494
35T Ring Gear **x2**

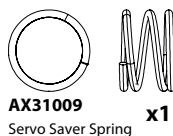

AX31009
Servo Saver Spring **x1**

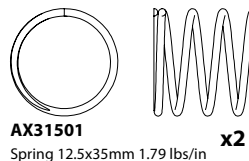

AX31501
Spring 12.5x35mm 1.79 lbs/in **x2**

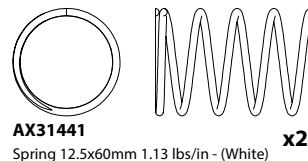

AX31441
Spring 12.5x60mm 1.13 lbs/in - (White) **x2**

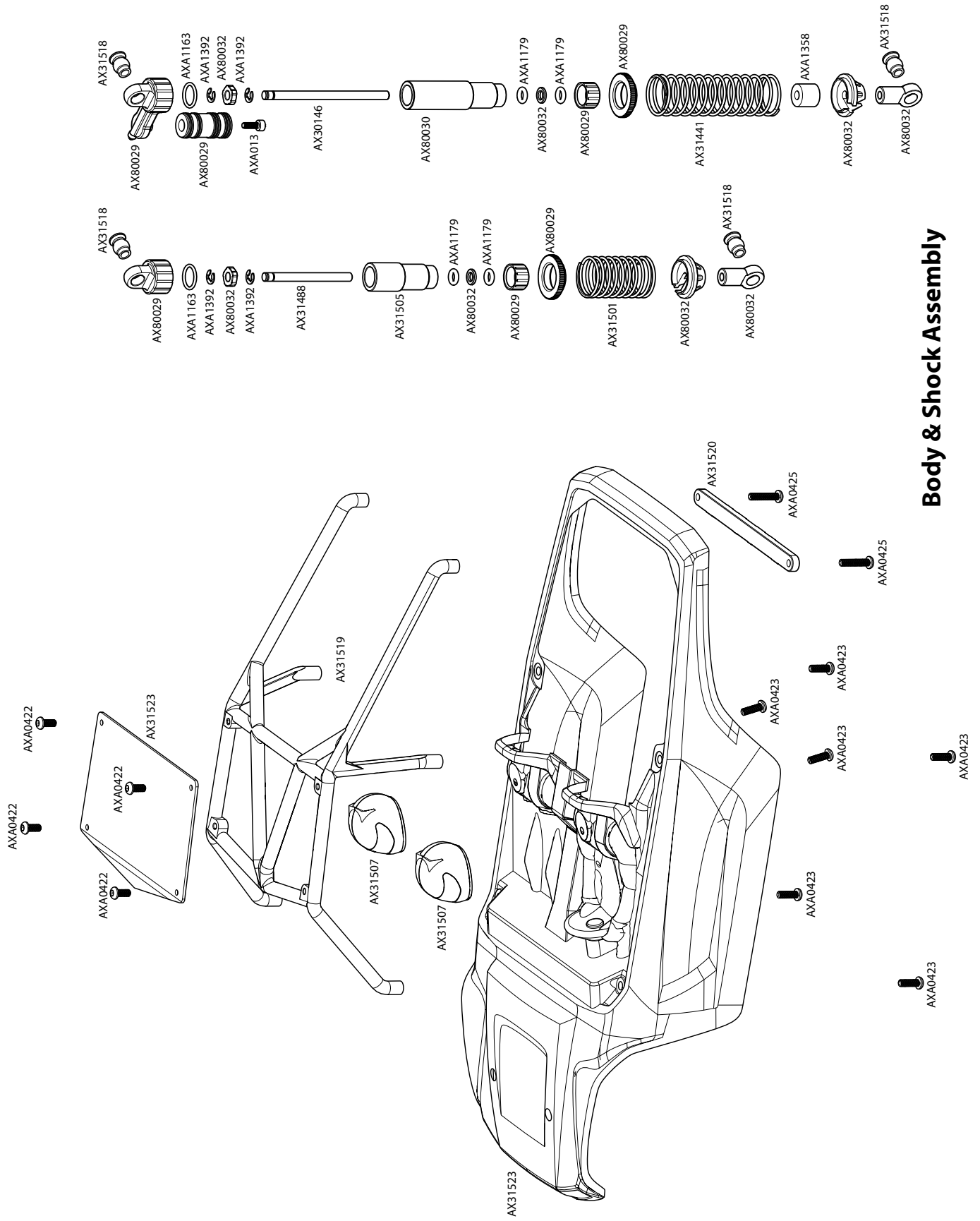

Body & Shock Assembly

Body & Wheel Assembly

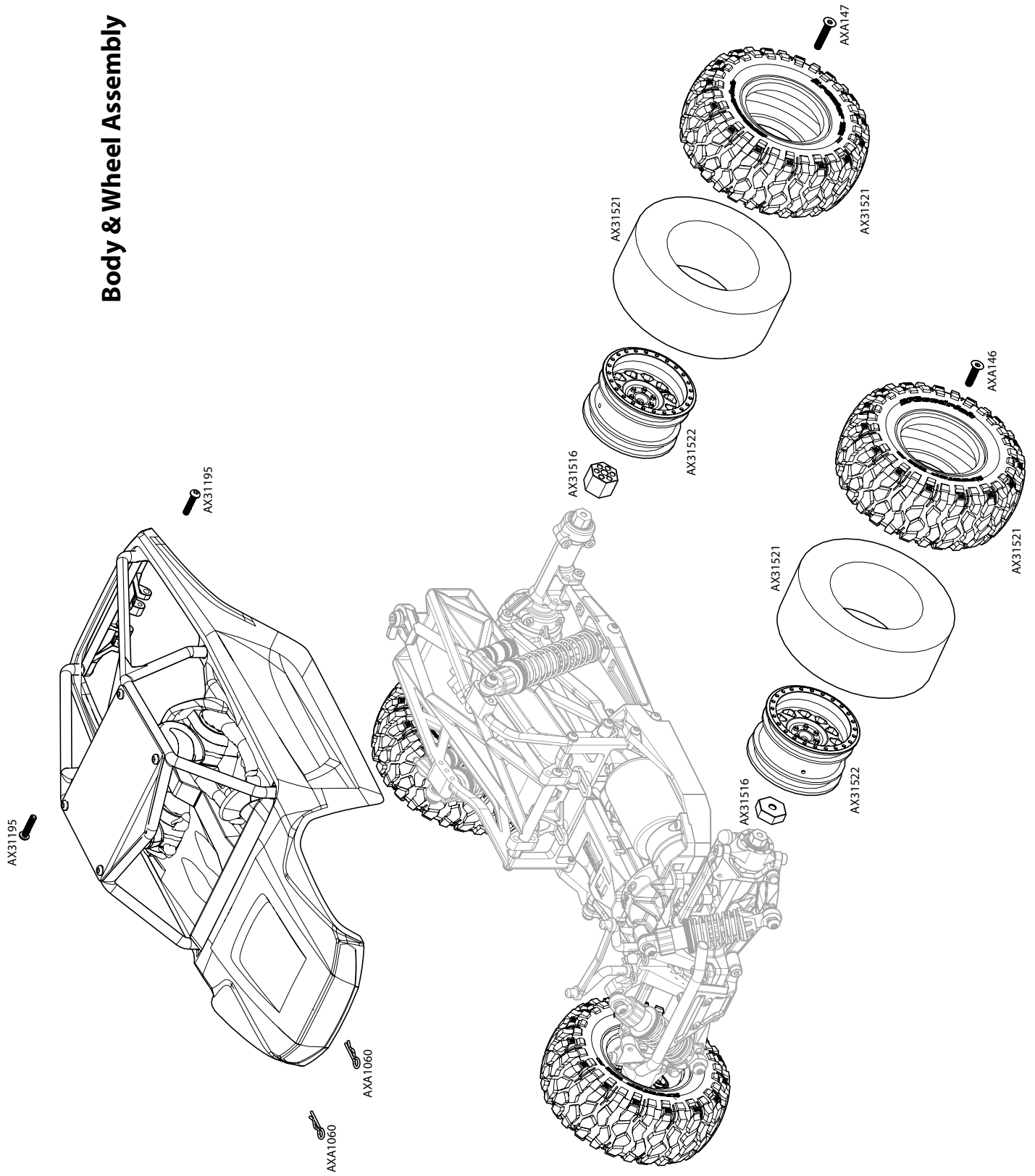

Parts List

Part #	Description
AX30146	Shock Shaft 3x50 (2pcs)
AX30162	Pin 1.5x8mm (6pcs.)
AX30168	Pin 2x8mm (6pcs.)
AX31009	2-Speed Hi/Lo Servo Saver Set
AX31195	M2.6x12mm Hex Socket Button Head (Black) (10pcs)
AX31280	M2.6x6mm Hex Socket Button Head (Black) (10pcs)
AX31289	Shim 10x8x0.3mm (6pcs)
AX31374	3mm Body Clip (Black) (10pcs)
AX31398	M2.6x12mm Cap Head (Black) (10pcs)
AX31399	M2.6x18mm Cap Head (Black) (10pcs)
AX31441	Spring 12.5x60mm 1.13 lbs/in - (White) (2pcs)
AX31488	Shock Shaft 3x35mm (2pcs)
AX31489	M2.5x6x10mm Hex Socket Button Head Shoulder Screw (Black) (6pcs)
AX31490	M2.5x6x12mm Hex Socket Button Head Shoulder Screw (Black) (6pcs)
AX31491	M2.6x18mm Hex Socket Button Head (Black) (10pcs)
AX31492	M2.6x40mm Cap Head (Black) (6pcs)
AX31493	M2.6x25mm Cap Head (Black) (6pcs)
AX31494	Bevel Gear Set - 35/15T
AX31495	Bearing 8x12x3.5mm (2pcs)
AX31496	Pinion Gear 48P 10T (2.3mm Motor Shaft)
AX31497	Pin 2x20mm (6pcs)
AX31499	Ball Stud 4mm M2.6x5mm (4pcs)
AX31501	Spring 12.5x35mm 1.79 lbs/in - (2pcs)
AX31502	Universal Joint Axle Set 48mm (2pcs)
AX31504	Hinge Pin 2.5x19mm (2pcs)
AX31505	46-63mm Shock Body Set
AX31506	Yeti Jr.™ Molded Chasis Tub
AX31507	Jr. Helmet Set (White)
AX31508	Yeti Jr.™ Rear Cage Battery Tray
AX31509	Differential Outputs Set
AX31510	AR18 Axle Housing
AX31511	Dogbone and Center Driveline Set
AX31512	Yeti Jr.™ Chassis Components
AX31513	Spur Gear 48P 60T
AX31514	Yeti Jr.™ Front Lower Control Arm Set
AX31515	Yeti Jr.™ Front Carrier Set
AX31516	Yeti Jr.™ Steering Knuckle Set
AX31517	Yeti Jr.™ Front Shock Tower and Bumper Set
AX31518	Yeti Jr.™ Rear Axle Link Set
AX31519	Yeti Jr.™ Body Cage
AX31520	Yeti Jr.™ Battery Door
AX31521	1.55 BFGoodrich Krawler T/A Tires 3.2" - R35 Compound (2pcs)
AX31522	1.55 Method Beadlock Style Wheels (Black) (2pcs)
AX31523	Yeti Jr.™ Body - .040" (Clear)
AX31538	M2.6x10mm Hex Socket Button Head (Black) (10pcs)
AX31542	M2x12mm Hex Socket Button Head (Black) (10pcs)
AX31543	Washer 2x7x.05mm (10pcs)
AX80029	Shock Cap Parts Tree
AX80030	61-90 Schock Body Set
AX80032	Shock Parts
AXA0023	M2.6x8mm Cap Head (Black) (10pcs)
AXA013	M2x6 mm Cap Head (Black) (10pcs)
AXA0147	M3x16mm Hex Socket Flat Head (Black) (10pcs)
AXA0413	M2.6x8mm Hex Socket Tapping Flat Head (Black) (10pcs)
AXA0414	M2.6x10mm Hex Socket Tapping Flat Head (Black) (10pcs)
AXA0422	M2.6x6mm Hex Socket Tapping Button Head (Black) (10pcs)
AXA0423	M2.6x8mm Hex Socket Tapping Button Head (Black) (10pcs)
AXA0425	M2.6x12mm Hex Socket Tapping Button Head (Black) (10pcs)
AXA1041	M2.5 Nylon Locking Hex Nut - Silver (10pcs)
AXA1163	O-Ring 7x1mm (10pcs)
AXA117	M3x15mm Hex Socket Button Head (Black) (10pcs)
AXA1179	O-Ring 2.5x1.5mm (10pcs)
AXA1218	Bearing 5x10x4mm (2pcs)
AXA1358	Shock Damper 3x7x8 (10pcs)
AXA1392	E2 e-clip (10pcs)
AXA146	M3x12mm Hex Socket Flat Head - Black (10pcs)
AXA180	M3x3mm Set Screw (Black) (10pcs)

OFFICIALLY LICENSED TECHNICAL PARTNERS:



EXPLORE

facebook.com/axialinc | instagram.com/axialracing | twitter.com/axialrc
youtube.com/axialvideos | flickr.com/axialrc



BFGoodrich® Tires and KRAWLER™ T/A® Trademarks are used under License from Michelin

©2016 Axial R/C, Inc. A subsidiary of Hobbico, Inc. All Rights Reserved.

AX90054-1001
2803877